



LG20D(T)III/ LG25D(T)III LG30D(T)III/LG35D(T)III

**INTERNAL COMBUSTION FORKLIFT
THE 3RD GENERATION FORKLIFT APPEARANCE**

EQUIPADO CON MOTOR XINCHAI O IMPORTADO
MOTOR DISEÑO ERGONOMICO AVANZADO GRANDE
RADIADOR DE CAPACIDAD DOBLE ESTRUCTURA SUSPENDIDA
VISTA AMPLIA MAST



LONKING 龙工

Efficiency Rules the Future

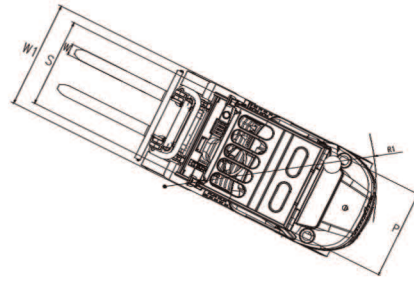
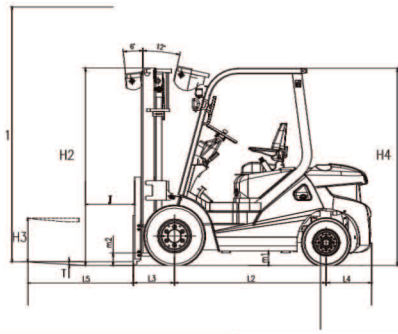

MODELO	LG20D(T)III	LG25D(T)III	LG30D(T)III	LG35D(T)III
Tipo de energía	Diesel	Diesel	Diesel	Diesel
Capacidad nominal	2000	2500	3000	3500
Centro de carga J	500	500	500	500
H1 STD Altura de elevación máxima	4500	4500	4500	4500
H3 Altura de elevación libre	110	110	125	170
L5 * W * T STD Tamaño de la horquilla	1070×120×40	1070×120×40	1070×125×45	1070×125×50
Ángulo de inclinación del mástil	6/12	6/12	6/12	6/12
Saliente frontal L3 (mm)	448	448	487	498
L4 voladizo trasero (mm)	500	500	550	580
Dimensión global				
L1 Longitud total (con horquilla) (mm)	3670	3670	3857	3898
W1 Anchura total (mm)	1165	1165	1250	1250
H2 STD Altura bajada del mástil (mm)	2135	2135	2132	2132
H4 Altura del guardabarros superior (mm)	2130	2130	2150	2150
R1 Radio de giro (mm)	2300	2300	2520	2530
Min. inserción del pasillo (mm)	3950	3950	4200	4225
Fecha de rendimiento				
Vel de desp máx. (Km / h) carga / descarga	18.5/20	18.5/20	18.5/20	18.5/20
Vel de elevación máx. (Mm / s) carga / descarga	560/580	560/580	500/520	400/420
Max.gradient (%)	20	20	20	20
Peso propio (kg)	3260	3500	4200	4635
Pisada S / P (delantera / trasera) (mm)	970/980	970/980	1030/980	1030/980
Distancia del eje L2 (mm)	1650	1650	1750	1750
Min. Distancia al suelo	M2 mástil (mm)	135	135	132
	Marco M1 (mm)	160	160	165
Motor STD	XINCHAI C490BPG	XINCHAI C490BPG	XINCHAI C490BPG	XINCHAI A498BT1
Potencia nominal (kw)	36.8	36.8	36.8	36.8

Motor opcional (2t&2.5t)					
Modelo de motor	Fabricante	Potencia nominal (kw / rpm)	Max torque (nw / rpm)	Diámetro / Número de cilindros / Desplazamiento	El consumo de combustible
C490BPG-47	China	36.8/2650	156/1800	90/4/2.67	230
A498BT1(2.5T)	China	36.8/2650	180/1800	98/4/3.17	230
C240	ISUZU	34/2500	137/1800	86/4/2.369	292

Motor opcional (3t&3.5t)					
Modelo de motor	Fabricante	Potencia nominal (kw / rpm)	Max torque (nw / rpm)	Diámetro / Número de cilindros / Desplazamiento	El consumo de combustible
C490BPG-47(3T)	China	36.8/2650	156/1800	90/4/2.67	230
C240	ISUZU	34/2500	137/1800	86/4/2.369	292
4JG2	ISUZU	44/2450	186/1700	95/4/3.059	265
S4S-474	MITSUMKISHI	36.8/2300	176/1800	120/4/3.331	225
A498BT1	China	36.8/2400	180/1800	98/4/3.17	230